

# AXV7607 High Voltage SMU



## Technical Data Sheet

### Features

PXI

VXI

LAN

cPCI

PXIe

GPIB

USB

RS232  
485

external  
PCIe

- Extremely low noise with linear output stage
- Output voltage from -1 500 V up to 2 500 V
- Very fast rise and fall times
- Output current in pulse mode max  $\pm 30$  mA
- Output current in continuous mode maximum  $\pm 8$  mA
- Integrated voltage measurement unit
- Integrated current measurement unit
- Integrated voltage monitor
- Integrated current monitor

## Product Information

The AXV7607 high voltage SMU is developed for fast semiconductor and cable testing. The AXV7607 can be used as a voltage or current source.

To maximize the test throughput the AXV7607 provides a bipolar MOSFET power amplifier with a programmable slew rate of up to 1 000 V/ms.

The AXV7607 provides five current ranges and is able to generate currents down to the nA range. In conjunction with the integrated Voltage Measurement Unit (VMU) all requirements of high voltage semiconductor testing can be met. The integrated guard amplifier can be used to drive the cable shielding and reduce the leakage current in the DUT cabling.

The integrated Current Measurement Unit (CMU) is extremely fast and is equipped with seven measurement ranges. This allows current measurement down to the pA range. With parallel trigger signals VMU and CMU can do synchronous measurements.

Monitoring of high output voltages with external equipment is a great safety problem. Therefore the AXV7607 is equipped with a fast voltage monitor, which provides a divided output voltage for safe monitoring. Precise monitoring of very low currents down to pA with external equipment is usually very difficult and special equipment is needed. To simplify this task, the AXV7607 provides a fast current monitor.

In the integrated relay matrix all high voltage signals (FORCE, SENSE, GUARD) are connected via relays to the output. Additional relays and switchable resistors provide self test capabilities.

All AXV7607 high voltage outputs (FORCE, SENSE, GUARD) and the monitor outputs are short circuit protected.

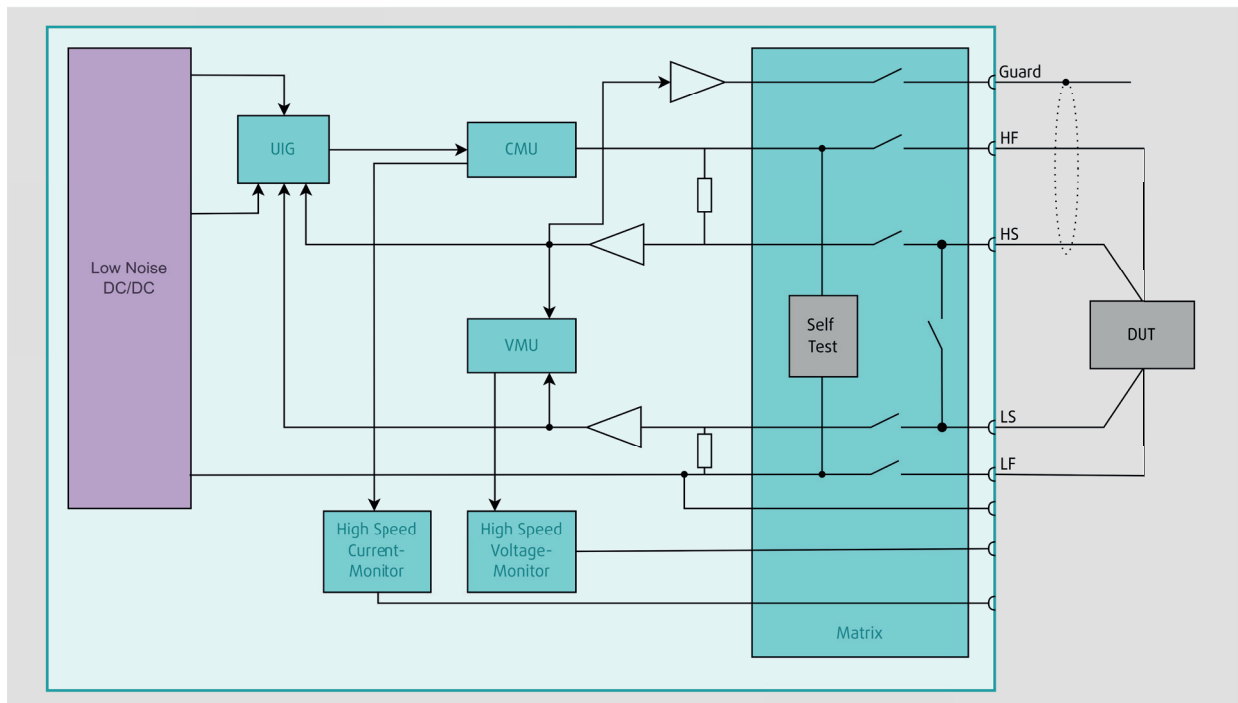

# General Specification

General	Specification
AC line voltage	230 V <sub>AC</sub> ± 10 %
AC line frequency	47 Hz ... 63 Hz
Power consumption	<10 W
Operating temperature	0 ... 50 °C
Operating altitude	<2 000 m
Relative humidity	Up to 85 % at 35 °C
Storage temperature range	-25 ... 70 °C
Size	19" x 3 U x 555 mm
Weight	≈15 kg
Electrical safety	According EN61010-1
Isolation output LF to PE	Direct connection of LF to PE

## Voltage Control Unit

Voltage Control Unit	Specification	Comment
Resolution	16 Bit	In all ranges
Compensation units	7	3 assembled, 4 arbitrary
DC Accuracy		
Gain error	±0.05 % of full scale	
Offset error	±0.05 % of full scale	
Maximum capacitive load	20 nF	
Guard buffer	2 mA	
Slew rate	10 ... 1 000 V/ms	Programmable range

## Current Control Unit

Current Control Unit	Specification	Comment
Resolution	16 Bit	In all ranges
Compensation units	7	3 assembled, 4 arbitrary
Range 1	-10 μA <sub>DC</sub> ... +10 μA <sub>DC</sub>	Programmable range
Gain error	±0.2 % of value	
Offset error	±0.2 % of full scale	
Range 2	-100 μA <sub>DC</sub> ... +100 μA <sub>DC</sub>	Programmable range
Gain error	±0.1 % of value	
Offset error	±0.1 % of full scale	
Range 3	-1 mA <sub>DC</sub> ... +1 mA <sub>DC</sub>	Programmable range
Gain error	±0.1 % of value	
Offset error	±0.1 % of full scale	
Range 4	-10 mA <sub>DC</sub> ... +10 mA <sub>DC</sub>	Programmable range
Gain error	±0.1 % of value	
Offset error	±0.1 % of full scale	
Range 5	-30 mA <sub>DC</sub> ... +30 mA <sub>DC</sub>	Programmable range
Gain error	±0.1 % of value	(maximum pulse length 10 ms <sup>1</sup> )
Offset error	±0.1 % of full scale	

<sup>1</sup> Cooling is designed for maximum pulse/pause ratio of 1:5!

**Notes:** All product data are specified for 1 year at an ambient temperature of 23°C ±5°C (after 1 hour warm-up time). Product specification and description in this document are subject to change without notice.

## Voltage and Current Measurement Unit

Voltage Measurement Unit	Specification	Current Measurement Unit	Specification
<b>Resolution</b>	16 Bit	<b>Resolution</b>	16 Bit
<b>Maximum input voltage</b>	2 500 V	<b>Overload protection</b>	180 mA in all ranges
<b>Filter frequencies</b>	100 Hz, 1 kHz, 10 kHz, 100 kHz	<b>Filter frequencies</b>	100 Hz, 1 kHz, 10 kHz, 100 kHz
<b>DC accuracy<sup>1</sup></b>		<b>DC accuracy<sup>1</sup></b>	
Range 1 V	±0.3 % of full scale	Range 100 nA	±0.5 % of full scale
Range 10 V	±0.1 % of full scale	Range 1 µA	±0.2 % of full scale
Range 100 V	±0.1 % of full scale	Range 10 µA	±0.1 % of full scale
Range 1 kV	±0.1 % of full scale	Range 100 µA	±0.1 % of full scale
Range 10 kV	±0.1 % of full scale	Range 1 mA	±0.1 % of full scale
		Range 10 mA	±0.1 % of full scale
		Range 100 mA	±0.1 % of full scale

<sup>1</sup> Specification takes effect with 100 Hz filter frequency and 20 consecutive measurement with an interval of 1 ms.

## Voltage and Current Monitor

Voltage Monitor	Specification	Current Monitor	Specification
<b>Output voltage</b>	+5V equivalent to +Full scale in each range	<b>Output voltage</b>	+5V equivalent to +Full scale in each range
<b>Internal resistance</b>	10 k	<b>Internal resistance</b>	10 k
<b>Accuracy</b>	±5 % of full scale	<b>Accuracy</b>	±5 % of full scale

## Ordering Information

Ordering Information	Comment
<b>AXV7607-1500</b>	Range: -1 500 V ... +1 500 V
<b>AXV7607-2500</b>	Range: 0 V ... +2 500 V
<b>Option GPIB<sup>2</sup></b>	GPIB Interface
<b>Option USB<sup>2</sup></b>	USB 2.0 Interface
<b>Option LAN<sup>2</sup></b>	Ethernet Interface
<b>Option FE</b>	Front touch display
<b>Option RMK</b>	19" rack mounting kit

<sup>2</sup> One of the interface options or the front panel is mandatory.